



# POWER HOUSE

## XRGI® IN OUTDOOR USE

Bespoke turnkey energy solution – individual, economical, flexible



**POWER**  
HOUSE

# The Power House at a glance

The Power House is EC POWER's all-in-one energy solution for residential, commercial, industrial and administrative buildings. It accommodates the complete heating centre in an exterior, quickly erected space – and gives you the numerous advantages of an efficient, space-saving energy supply tailored precisely to your needs.

The basis of every Power House is the modern cogeneration system from EC POWER. Inside it, one or more XRG1® cogeneration units simultaneously generate heat and power for direct use in the property. If the XRG1® produces more electricity than is consumed, you can automatically sell the surplus to the grid.

# As individual as your property

The EC POWER Power House is available in eight proven standard models that are perfectly suited for many applications. Alternatively, we design your Power House exactly according to your individual needs and the conditions of the property. Sufficient space for all boiler room components and turnkey delivery to the installation site are always included.

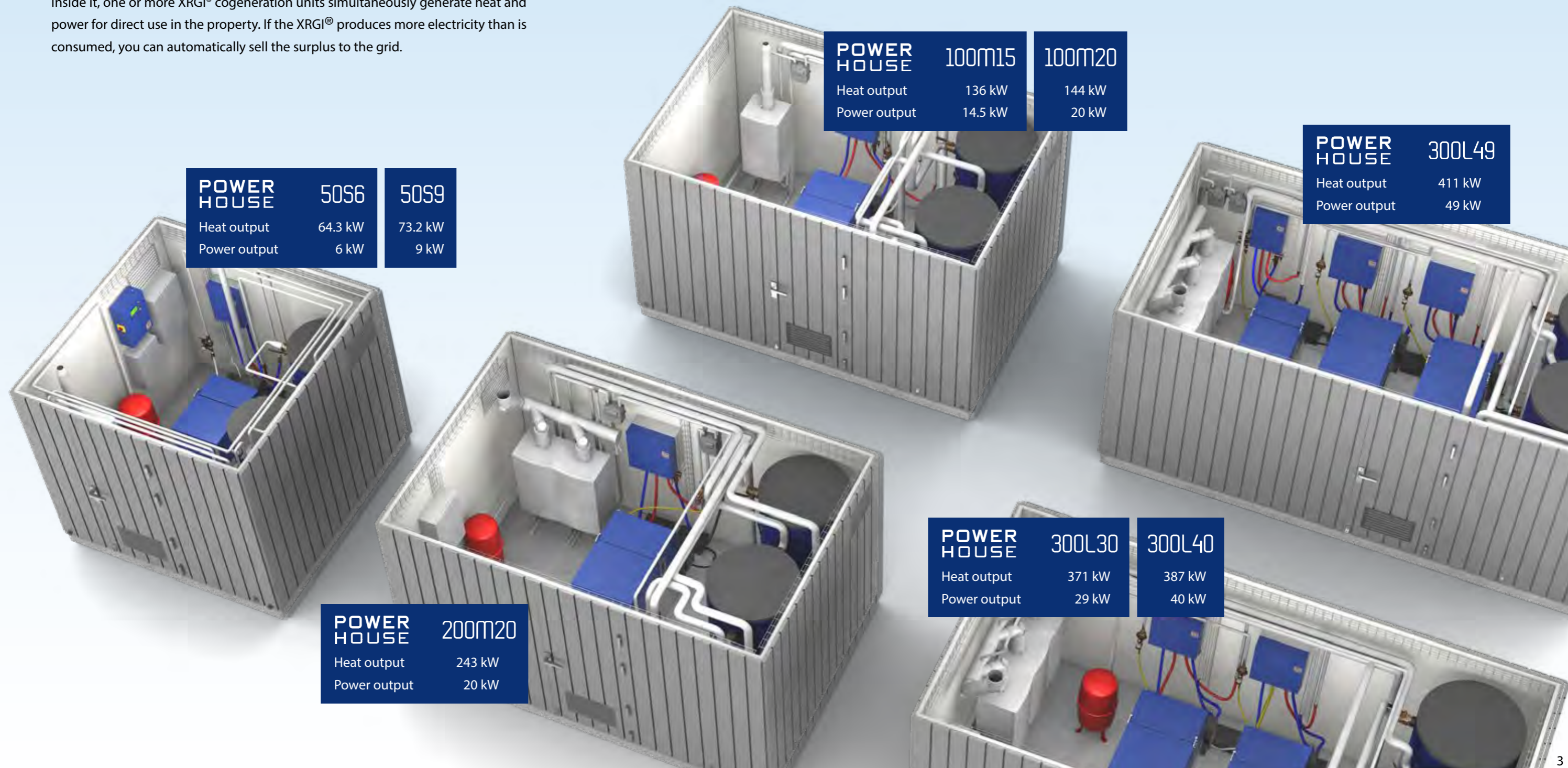



# Future-proof technology

Modern energy solutions have to meet strict requirements in terms of consumption and efficiency. That is no problem for EC POWER's Power House technology: it is based on a customised combination of several types of energy generation, with cogeneration at its core. Whether you are planning a new building or want to renovate an existing building: The Power House complies with the European country-specific building codes. Therefore, it ensures the best ratings for your overall building efficiency.

Moreover, thanks to its future-proof technology concept, which combines CHP, heatpumps and boilers for optimal energy efficiency, the Power House qualifies for subsidies in many countries within schemes for energy efficiency and renewable measures.



# Save time, money and space

With the Power House, you get more options for placing your energy solution: instead of occupying space inside the building, as is usually the case, it hides as a compact unit outside (side-by version) or on the roof of the building (rooftop solution). This means significantly more living space or usable space in your property. Are you modernising your heating system? Create more space at the same time and relocate your new XRGI® cogeneration unit and the complete energy supply into a Power House.

Due to the gain in interior space and the elimination of the chimney construction, the Power House almost funds itself. The low operating and energy costs do the rest. And thanks to turnkey delivery as well as assembly and connection by the experts from EC POWER, you also save valuable construction time.

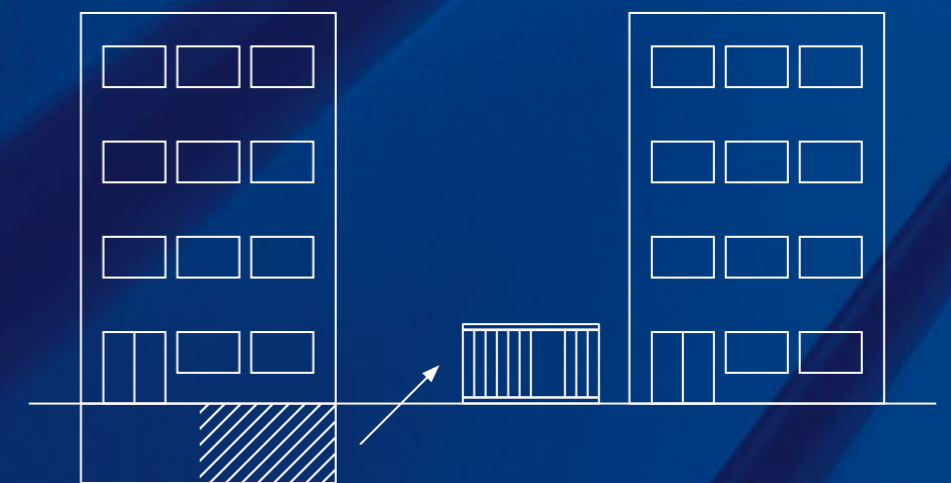





# Why Power House?

It's quite simple. The Power House from EC POWER combines the advantages of modern and efficient domestic energy technology with a well thought-out overall concept. It meets the highest environmental demands, ensures low operating costs and reliable system security – and is delivered turnkey, according to your exact specifications.



- An all-in-one energy solution located outdoors saves space in the building
- Ideal integration into your building concept as a side-by or rooftop version



- Intelligent system solution for decentralised power and heat generation from the technology-leading manufacturer EC POWER
- Highly efficient supply – even for multiple buildings



- Extremely short installation time due to our plug-and-play concept
- Easy access at any time enables fast service and repair



- Budget security thanks to a pre-fabricated standard installation concept
- Easy to set up thanks to minimal on-site requirements



- Individual equipment according to requirements
- Façade can be clad or painted as desired

SIDE-BY &  
ROOFTOP

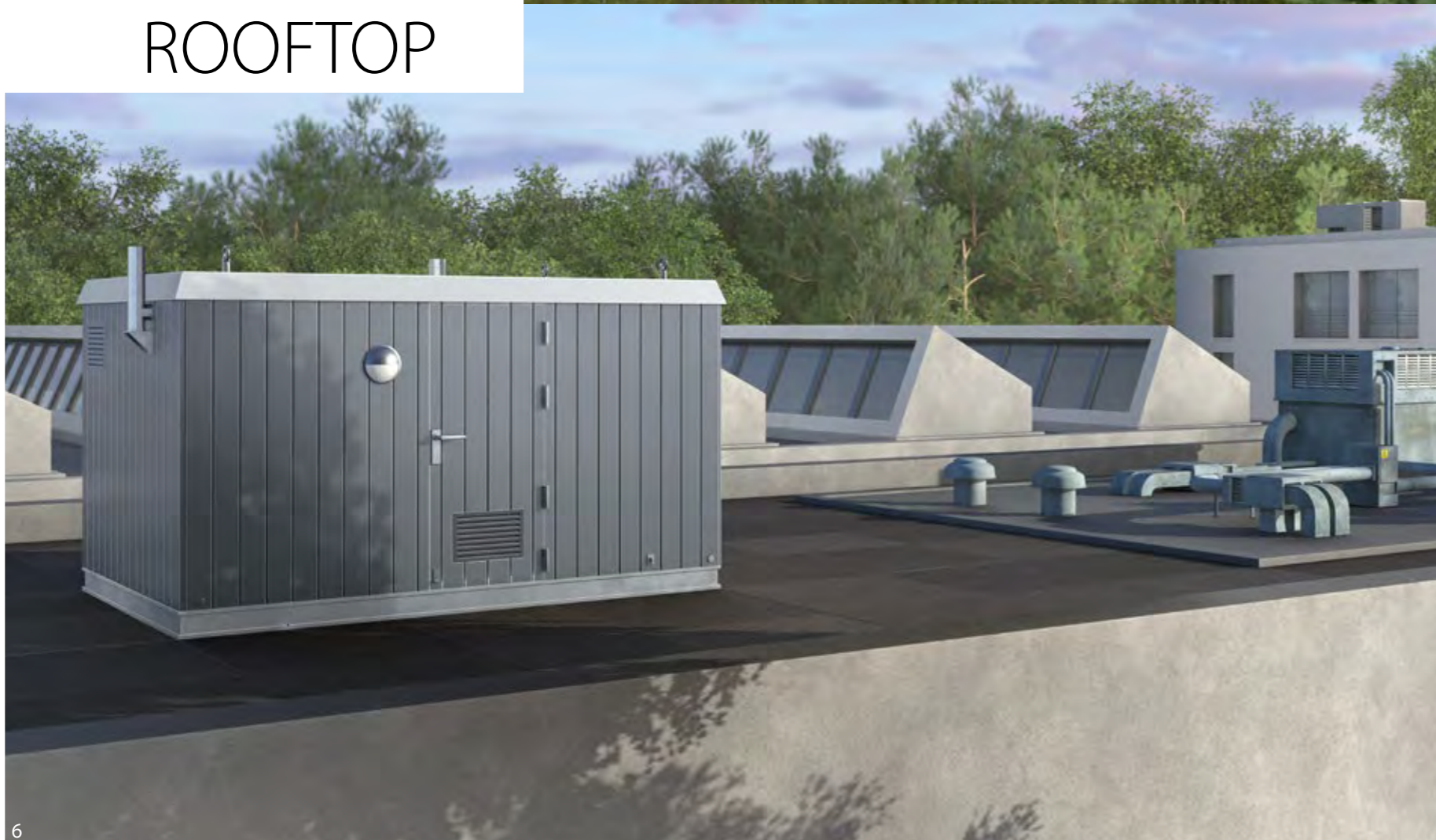



# The solid exterior

Your Power House is built as a robust, wind- and weather-protected outdoor unit that blends seamlessly into its surroundings. Shown is the standard version of the Power House, which you can expand individually with numerous additional options.

- 1 Power House total height 2,735 mm
- 2 Standard room height 2,375 mm
- 3 Standard door (1,000 mm x 2,240 mm) with panic function
- 4 External façade made of profiled alu-zinc sheeting 1.5 mm thick with corrosion protection (class 4)
- 5 100 mm insulation of the walls and roof (wall: 0.36 W/m<sup>2</sup>K, roof: 0.34 W/m<sup>2</sup>K)
- 6 Removable flat roof with 2° pitch, incl. insulation and rear ventilation to avoid condensation

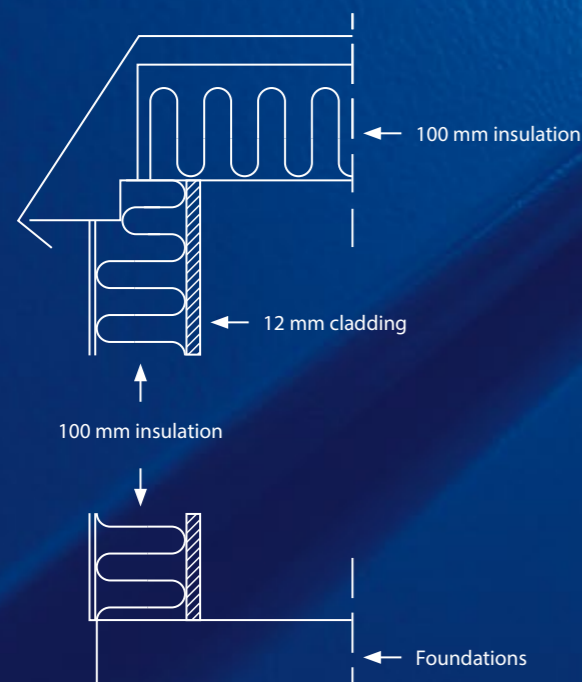

- 7 Two ventilation grilles (500 x 300 mm) in the outer wall and door for heat dissipation and cross-ventilation
- 8 Wall outdoor light
- 9 Solid concrete floor slab (160 or 200 mm thick) with steel reinforcement, alternatively steel foundations for on-roof installation

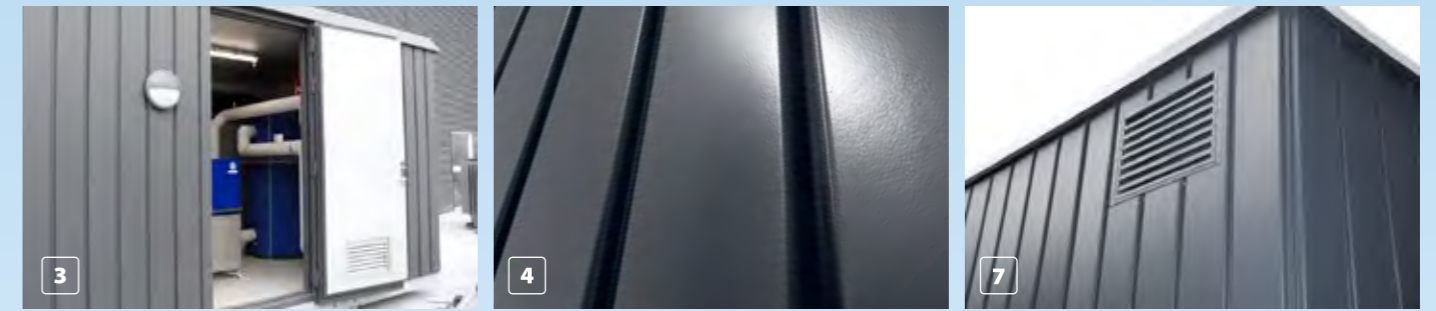



# The inner values

Inside the Power House, one or more XRGB® cogeneration units generate heat and electricity simultaneously. There is also enough space for all the other components of your heating system. Thanks to the ready-to-connect system technology, the Power House is ready for use in no time at all.

**1** Modern cogeneration technology from EC POWER for a sustainable heat and power supply with the lowest primary energy factors

- Coordinated hydraulics
- Intelligent storage management
- Database connection (EC POWER)
- Redundant heat supply for high reliability



**2** Two gas meters for easy billing

**3** High-performance storage tank

**4** 12 mm melamine panels (light grey), water-resistant

**5** Washbasin (optional)

**6** Roof feed-through of the exhaust pipes

**7** Pressure maintenance (MAG)

**8** Concrete floor (statically designed for high demands)

**9** Basic electric package consisting of interior lighting, socket, wall switch and electric wall heating for frost protection including fuse protection

**10** Mains feed pump and heating circuit control (optional)

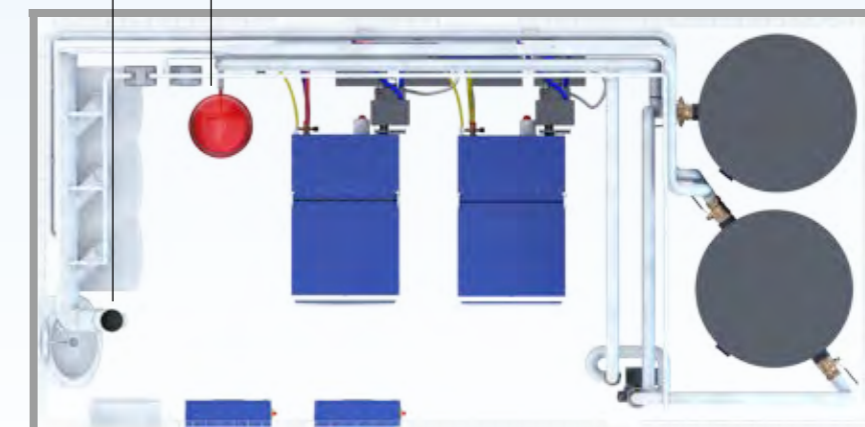
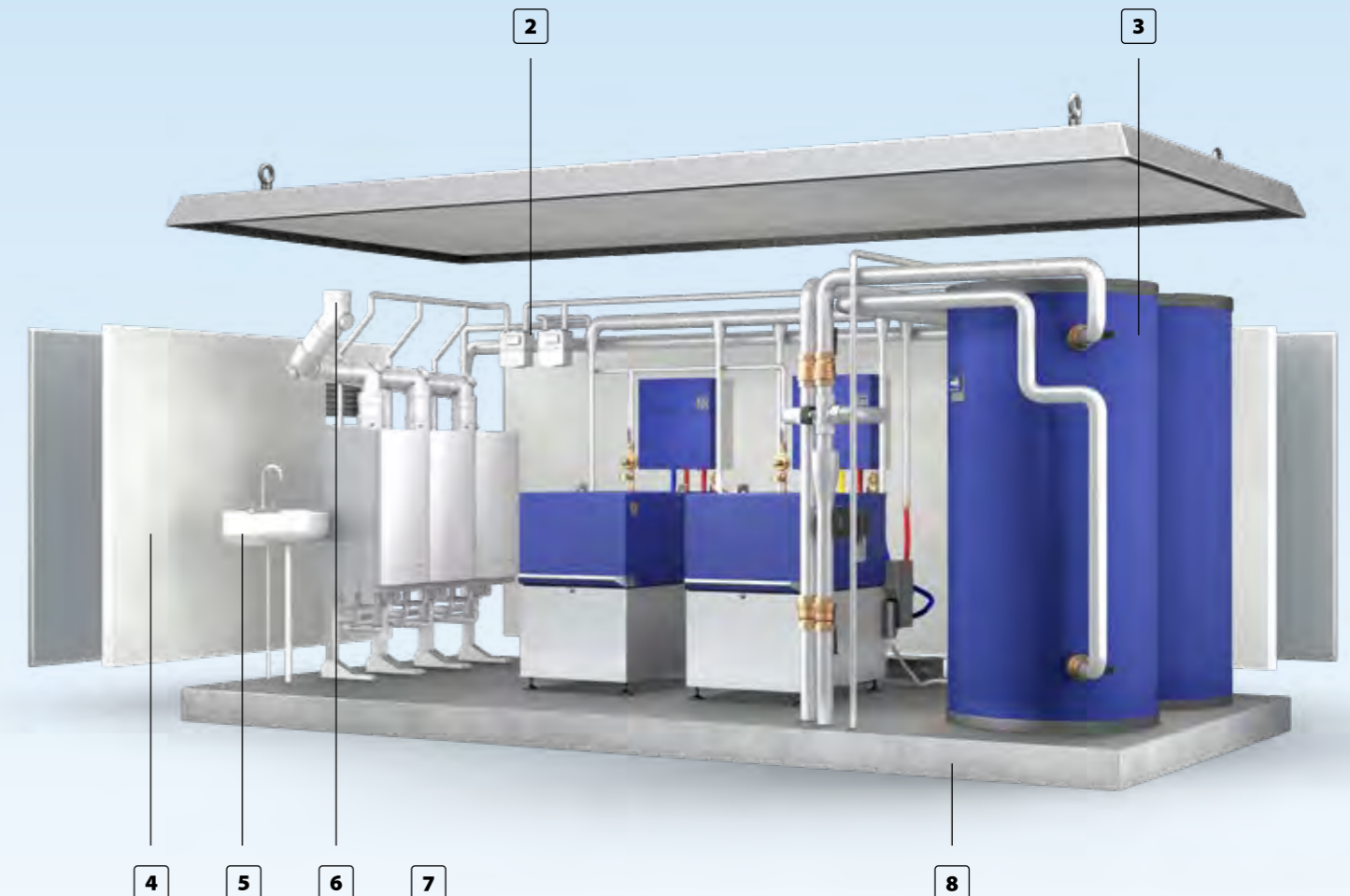



# Special equipment (optional)

Expand your Power House, design the façade and flooring, add additional technology or adapt it for an even better fit to the site. All this is possible with the Power House configurator.

- 1 Various surfaces and colours / Anti-graffiti coating / Increased corrosion class 5
- 2 Raising the roof by 20 cm
- 3 Extension by a house connection room (depth = 1,600 mm with double wing door)
- 4 Extension of the Power House in length
- 5 Gable roof

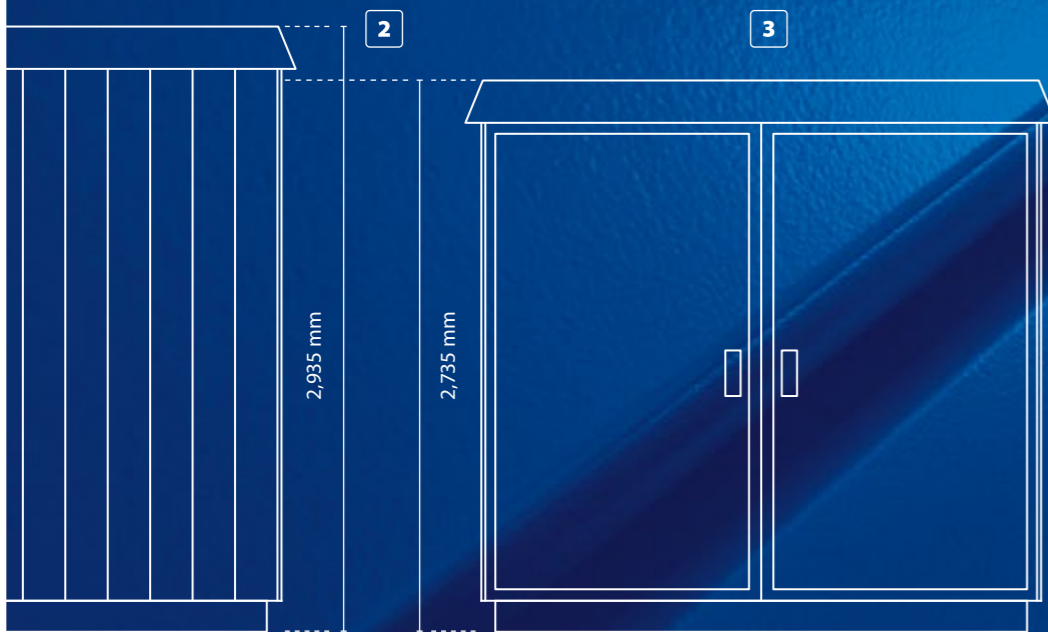

- 6 Additional sound insulation for the ventilation grilles
- 7 Gutter with downpipe
- 8 Double wing door
- 9 Floor coating with epoxy resin or quartz sand coating
- 10 Additional sound insulation of the doors and the cabin
- 11 Wall feed-through of the exhaust pipes
- 12 Steel substructure (instead of concrete) for on-roof installation
- 13 Climate package
- 14 E-charging station

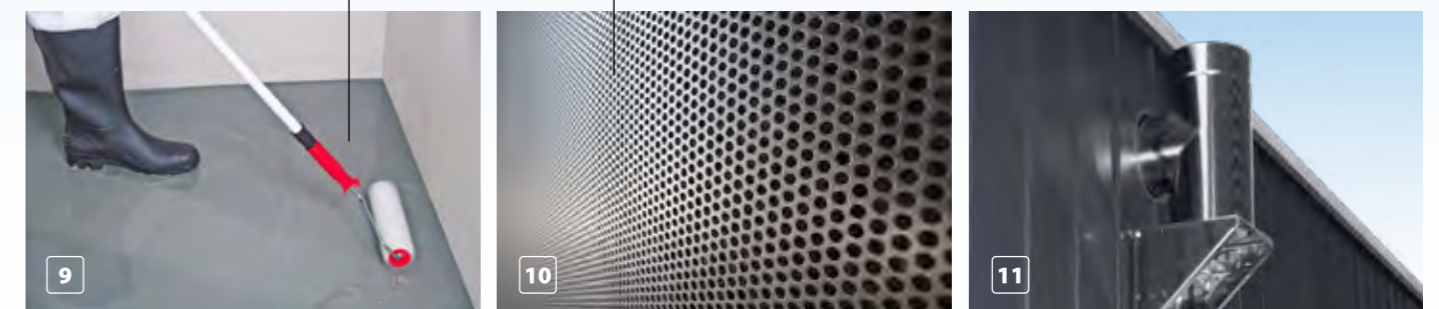



# Ground preparation

In order for your Power House to stand stable and secure, the ground must be prepared. Depending on the soil conditions, a simple sand bed or a strip foundation will suffice here.

## Sand bed

- The top layer of soil is removed until a load-bearing layer is achieved.
- The sand bed is piled up and compressed for sufficient load-bearing capacity. It must be 300 mm wider all round than the base plate of the Power House and project into the existing floor from the outer edge at an angle of 45°.
- When the groundwater level is above the freezing limit, additional catchment drains are drawn in to protect the sand bed from frost.

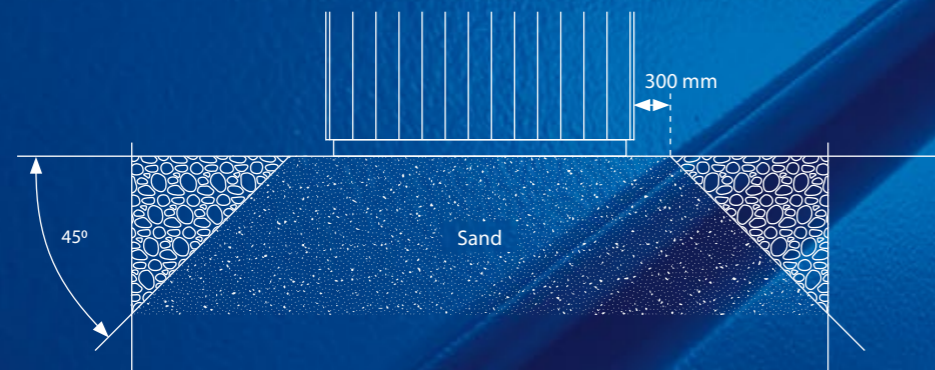

## Strip foundation

- In accordance with your Power House configuration, we will be happy to prepare a foundation plan for you using the outline of the excavated trench and the position of the cable bushing.
- The foundation should be approx. 200 mm wider all around than the base plate of the Power House.
- An additional clean layer of 100 mm around the concrete protects against weathering.
- Using formwork enables a much better alignment and smoothing of the foundation.

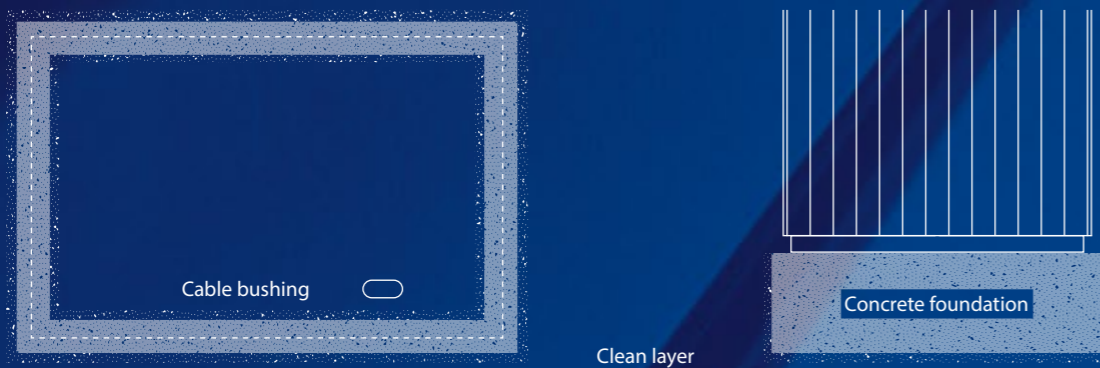

# Transport and connection

The Power House is lifted into its prepared place by a mobile crane. The pre-laid connections are connected to the Power House by heating and electronics professionals. It is immediately ready for use.



There are threads on the Power House for mounting stop swivels. The slings are attached to these. In order to ensure the vertical tension of the straps as well as a sufficient distance to roof projections or gutters, the use of a cross or H-beam of suitable size is recommended.

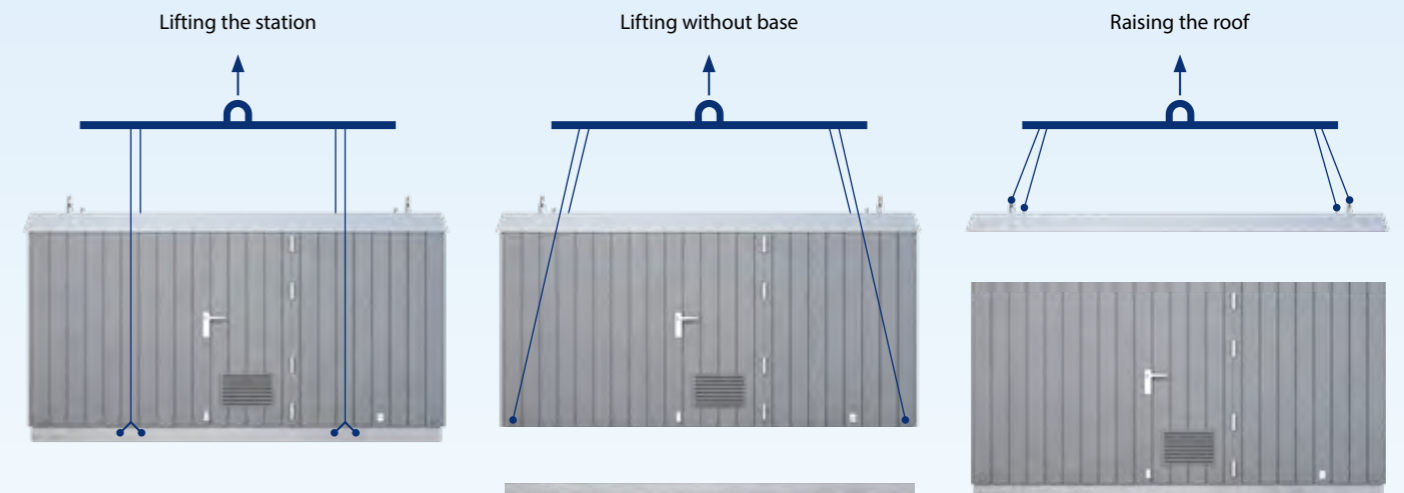

## The Power House on the roof

For on-roof installation, the Power House is supplied with a steel frame instead of a concrete slab as a substructure. An additional crane must be booked to bridge the height.





# Project procedure



## 1. Needs analysis

First, we listen to you, and we listen carefully: Which building is to be supplied? How big is it, how is it used? What is the energy demand? What proportion of this can, should, and must be covered by renewable sources? What other specific factors need to be considered with regard to building efficiency? Are there any special framework conditions beyond that?

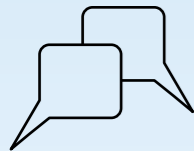

## 2. Consultancy

Based on the needs assessment, we develop various implementation options for your project. In doing so, we not only consider the economic conditions – such as potential savings and investment costs – as well as the legal requirements based on relevant country-specific building codes, but also advise you according to ecological criteria.

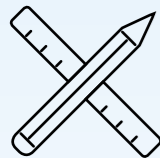

## 3. Planning / dimensioning

Once the decision for a solution has been made, our experts develop the ideal system configuration that will supply you with energy in a future-proof manner. In detailed planning, they tailor the technical equipment to your property and, if desired, also include financing options, and potential operator concepts.

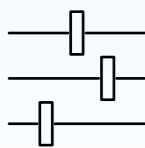

## 4. Individualisation

Our team will personally present the intended design to you. Various integration options and special solutions are available. Of course, your wishes for individual exterior design are also incorporated into the final concept.



## 5. Construction planning

Immediately after the contract is signed construction preparation begins. Our experts define schedules, coordinate the trades involved and thus ensure that the project runs smoothly.



## 6. Delivery

Delivery is straightforward: your customised Power House is brought to the site by truck and placed on the prepared site by crane. The sustainable and innovative energy supply for your property is now within reach.



## 7. Commissioning

Thanks to standardised interfaces, connection to the supply network is also quick and easy. Our team then ensures professional commissioning: the various system components are set in motion and expertly adjusted.



## 8. Maintenance / service

Even a Power House needs maintenance from time to time. Through our EC POWER partners, we offer maintenance and service options for every need, including full maintenance contracts for an all-inclusive process. Talk to us to find out more!



## 9. System monitoring

Our after-sales service can keep an eye on your new cogeneration unit at all times remotely and can react quickly if an exceptional technical situation makes it necessary.



# POWER HOUSE

## 50S6

## 50S9

POWER HOUSE	50S6	50S6 BW	50S9	50S9 BW
Total heating capacity	62.3 kW	64.3 kW	70.0 kW	73.2 kW
Weight of Power House / technology	~ 1,200 kg / ~ 2,200 kg			
Weight of concrete base plate / steel substructure	~ 4,000 kg / ~ 1,200 kg			
Storage tank volume	2 x 500 litres			
Heat meter	optional			
Grid connection for heat	DN 50 / flange			
Supply cable	400V / 3Ph / 3 x 32A + 230V / 1Ph / 1 x 16A			
Fresh water / waste water connection	DN 20 / min. DN 70			
Fuel	Natural gas / biomethane / liquefied petroleum gas			
Maximum gas intake (LCV)	74.0 kW		83.5 kW	
Heating demand	50,000 kWh/a			
Coverage share CHP	89.4 %	92.6 %	98.1 %	99.3 %
Heating demand	70,000 kWh/a			
Coverage share CHP	80.7 %	84.8 %	92.6 %	95.3 %
Heating demand	90,000 kWh/a			
Coverage share CHP	73.0 %	77.7 %	86.9 %	90.4 %
Heating demand	110,000 kWh/a			
Coverage share CHP	66.1 %	71.4 %	81.6 %	85.7 %

### PEAK LOAD BOILER

Thermal output, modulating (50/30 °C)	14.3 - 49.9 kW	14.3 - 49.9 kW	14.3 - 49.9 kW	14.3 - 49.9 kW

### COGENERATION UNIT

Manufacturer / model	EC POWER XRGI® 6	EC POWER XRGI® 6	EC POWER XRGI® 9	EC POWER XRGI® 9
Quantity	1	1	1	1
Condensing heat exchanger	No	Yes	No	Yes
Thermal output	12.4 kW	14.4 kW	20.1 kW	23.3 kW
Electrical output	6 kW	6 kW	9 kW	9 kW
Electricity ratio	0,480	0,416	0,448	0,386
Maximum flow temperature	~ 80 °C	~ 80 °C	~ 80 °C	~ 80 °C
Variable return temperature	5 °C to 65 °C	5 °C to 65 °C	5 °C to 65 °C	5 °C to 65 °C
Service interval (operating hours)	10,000	10,000	10,000	10,000



External dimensions: W = 3,000, H = 2,735, D = 3,000 mm

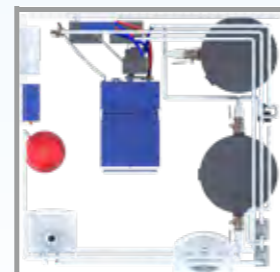

Internal dimensions: W = 2,775, H = 2,375, D = 2,775 mm

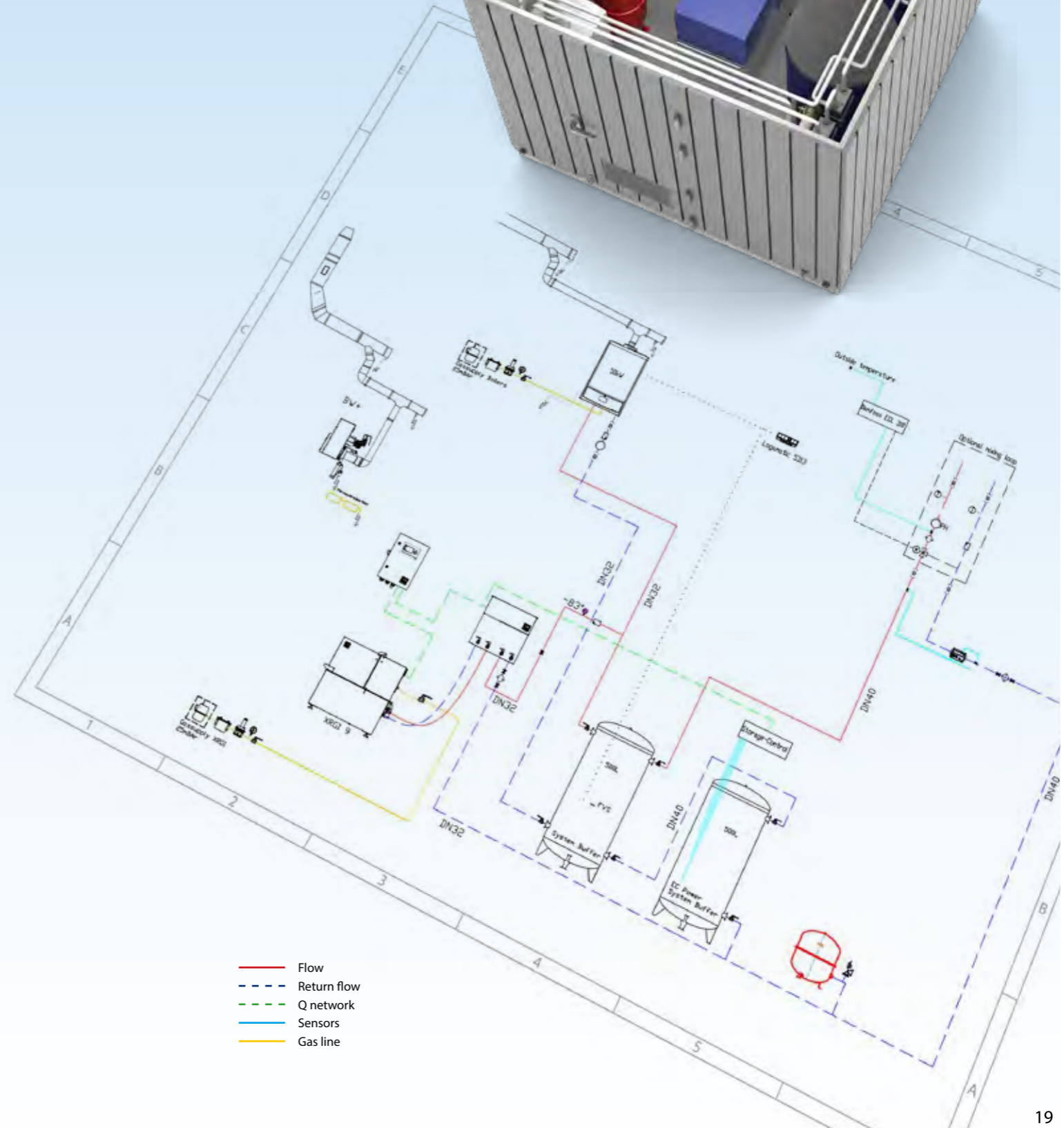
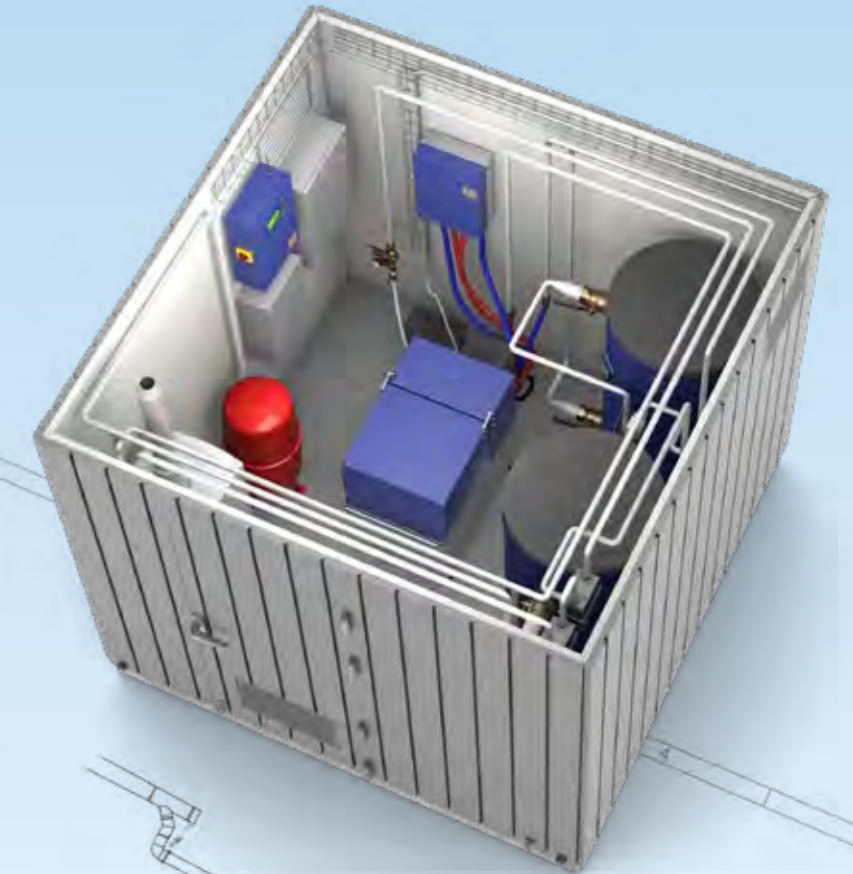

- Flow
- Return flow
- Q network
- Sensors
- Gas line



# POWER HOUSE

## 100M15 100M20

POWER HOUSE	100M15	100M15 BW	100M20	100M20 BW
Total heating capacity	130 kW	136 kW	138 kW	144 kW
Weight of Power House / technology	~ 1,500 kg / ~ 3,500 kg			
Weight of concrete base plate / steel substructure	~ 6,000 kg / ~ 2,200 kg			
Storage tank volume	2 x 1,000 litres			
Heat meter	optional			
Grid connection for heat	DN 50 / flange			
Supply cable	400V / 3Ph / 3 x 63A + 230V / 1Ph / 1 x 16A			
Fresh water / waste water connection	DN 20 / min. DN 70			
Fuel	Natural gas / biomethane / liquefied petroleum gas			
Maximum gas intake (LCV)	151.8 kW		163.6 kW	
Heating demand	120,000 kWh/a			
Coverage share CHP	92.9 %	95.7 %	95.4 %	97.8 %
Heating demand	180,000 kWh/a			
Coverage share CHP	84.1 %	88.2 %	98.4 %	92.3 %
Heating demand	240,000 kWh/a			
Coverage share CHP	75.4 %	81.1 %	82.6 %	86.2 %
Heating demand	300,000 kWh/a			
Coverage share CHP	66.4 %	73.5 %	75.5 %	80.4 %

### PEAK LOAD BOILER

Thermal output, modulating (50/30 °C)	31.2 - 99.5 kW	31.2 - 99.5 kW	31.2 - 99.5 kW	31.2 - 99.5 kW
---------------------------------------	----------------	----------------	----------------	----------------

### COGENERATION UNIT

Manufacturer / model	EC POWER XRGI® 15	EC POWER XRGI® 15	EC POWER XRGI® 20	EC POWER XRGI® 20
Quantity	1	1	1	1
Condensing heat exchanger	No	Yes	No	Yes
Thermal output	30.8 kW	36.7 kW	38.7 kW	44.7 kW
Electrical output	14.5 kW	14.5 kW	20.0 kW	20.0 kW
Electricity ratio	0.474	0.395	0.517	0.447
Maximum flow temperature	~ 85 °C	~ 85 °C	~ 85 °C	~ 85 °C
Variable return temperature	5 °C to 70 °C	5 °C to 70 °C	5 °C to 70 °C	5 °C to 70 °C
Service interval (operating hours)	8,500	8,500	6,000	6,000

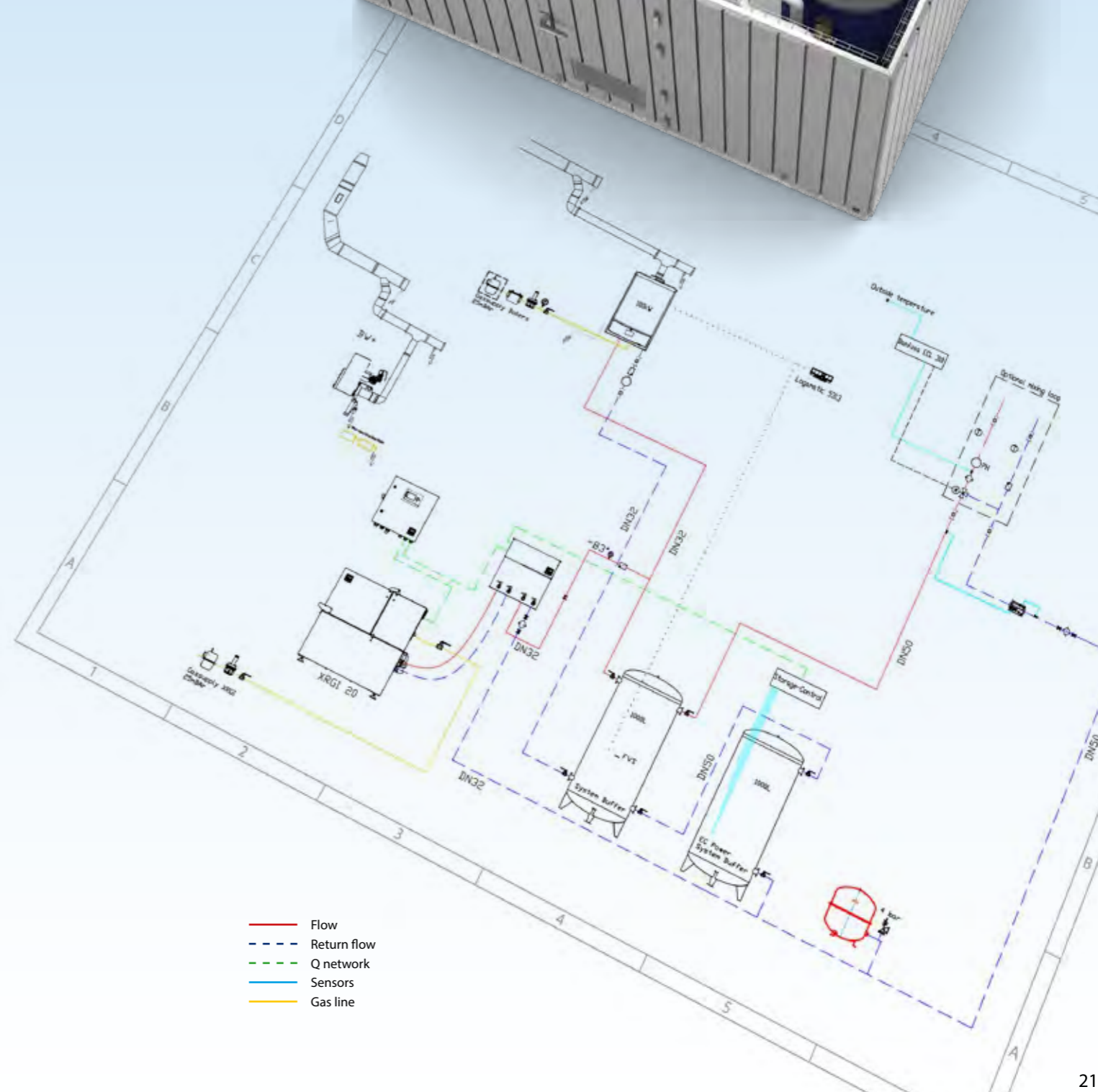
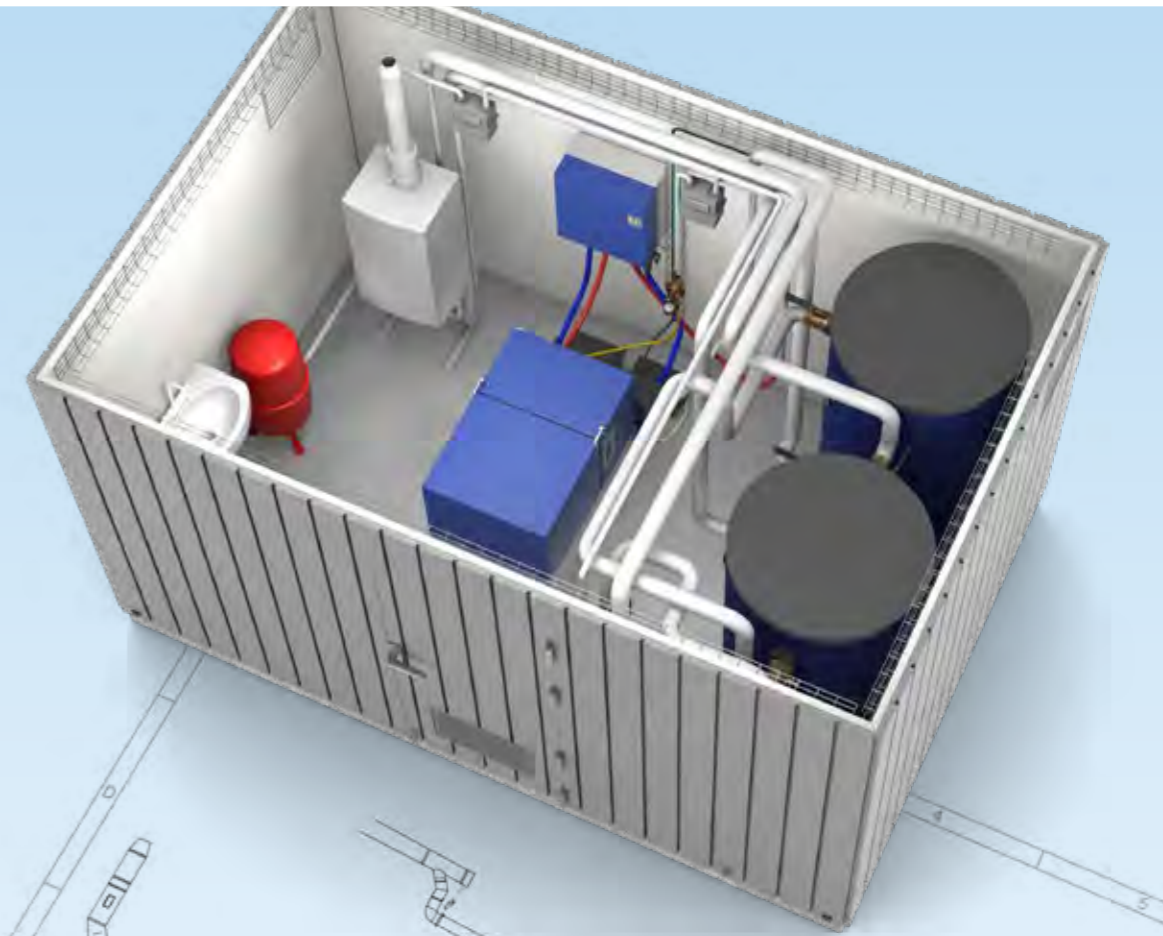

External dimensions: W = 4,600, H = 2,735, D = 3,000 mm

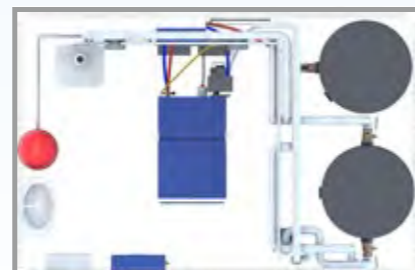

Internal dimensions: W = 4,375, H = 2,375, D = 2,775 mm



# POWER HOUSE

# 200M20

POWER HOUSE	200M20	200M20 BW
Total heating capacity	235 kW	243 kW
Weight of Power House / technology	~ 1,500 kg / ~ 3,500 kg	
Weight of concrete base plate / steel substructure	~ 6,000 kg / ~ 2,200 kg	
Storage tank volume	2 x 1,000 litres	
Heat meter	optional	
Grid connection for heat	DN 65 / flange	
Supply cable	400V / 3Ph / 3 x 63A + 230V / 1Ph / 1 x 16A central.: Supply line 400V / 3Ph / 63A	
Fresh water / waste water connection	DN 20 / min. DN 70	
Fuel	Natural gas / biomethane / liquefied petroleum gas	
Maximum gas intake (LCV)	265.9 kW	265.9 kW
Heating demand	260,000 kWh/a	
Coverage share CHP	80.3 %	84.2 %
Heating demand	320,000 kWh/a	
Coverage share CHP	73.1 %	78.3 %
Heating demand	380,000 kWh/a	
Coverage share CHP	66.1 %	72.0 %
Heating demand	440,000 kWh/a	
Coverage share CHP	60.1 %	69.9 %
<b>PEAK LOAD BOILER</b>		
Thermal output, modulating (50/30 °C)	31.2 - 199.0 kW	31.2 - 199.0 kW
<b>COGENERATION UNIT</b>		
Manufacturer / model	EC POWER XRG1® 20	EC POWER XRG1® 20
Quantity	1	1
Condensing heat exchanger	No	Yes
Thermal output	38.7 kW	44.7 kW
Electrical output	20.0 kW	20.0 kW
Electricity ratio	0.517	0.447
Maximum flow temperature	~ 85 °C	~ 85 °C
Variable return temperature	5 °C to 70 °C	5 °C to 70 °C
Service interval (operating hours)	6,000	6,000

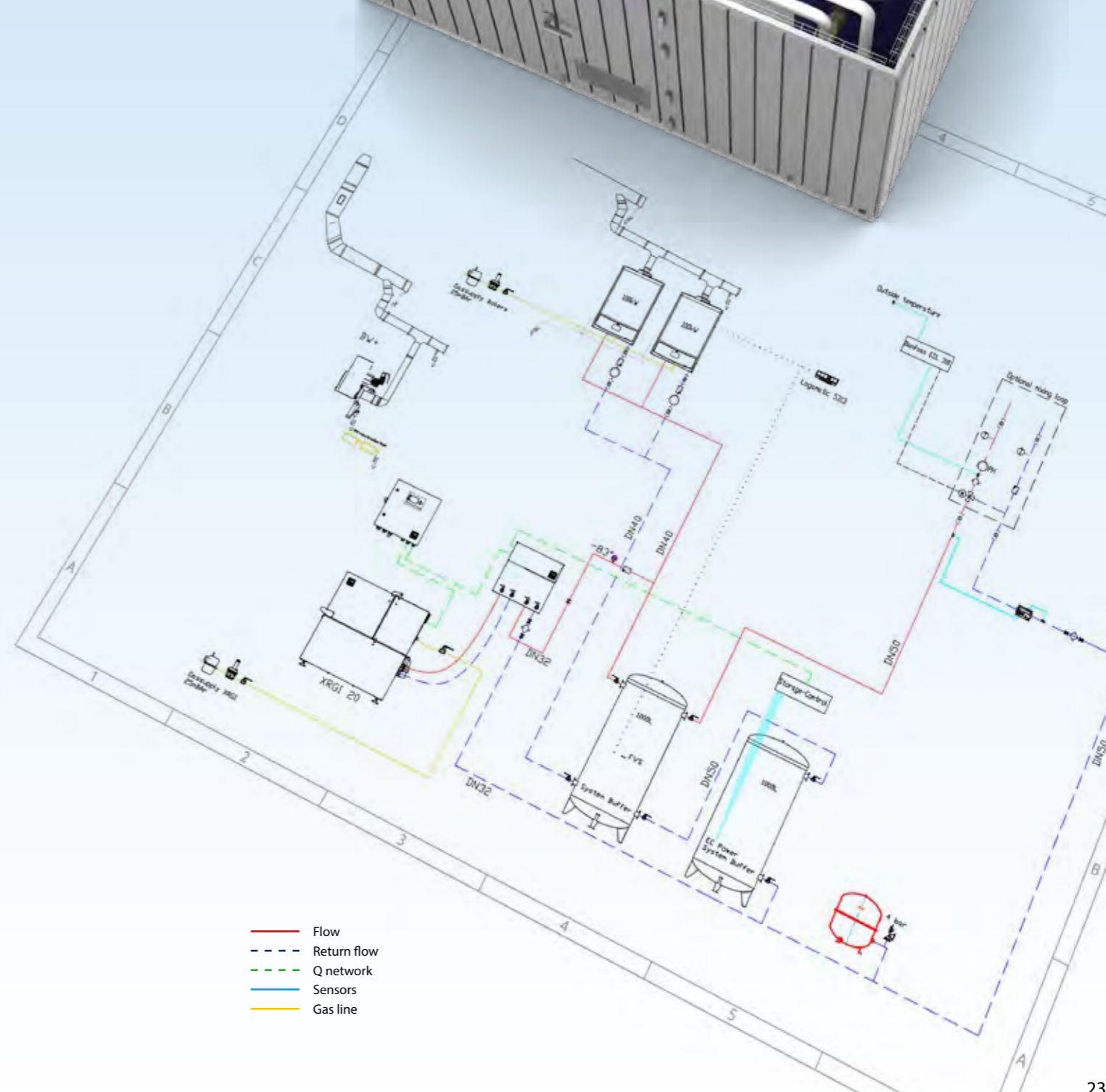
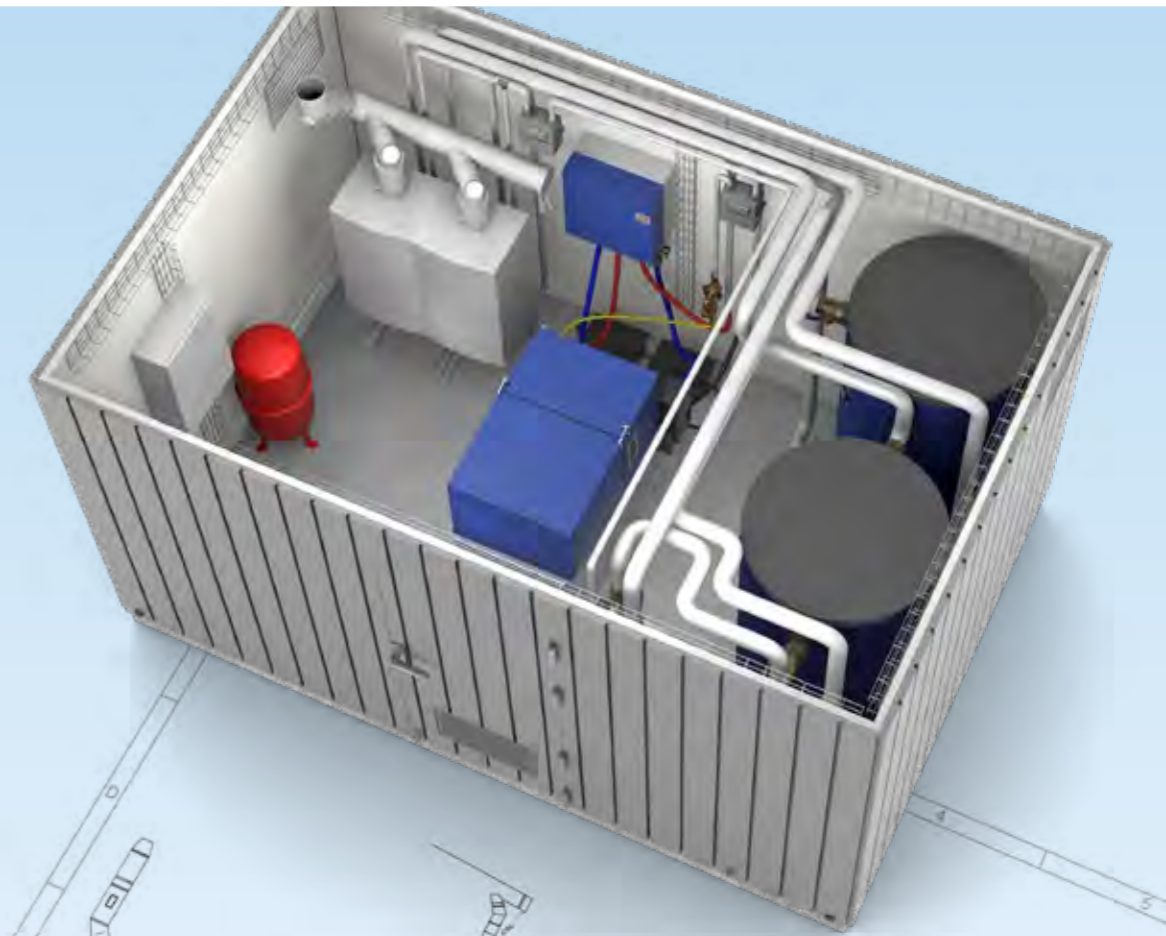

- Flow
- - - Return flow
- - - Q network
- Sensors
- Gas line



External dimensions: W = 4,600, H = 2,735, D = 3,000 mm

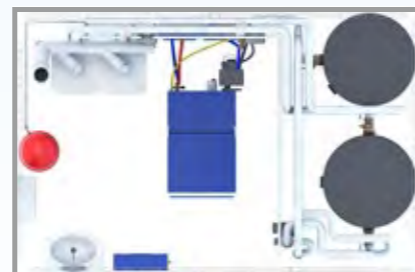

Internal dimensions: W = 4,375, H = 2,375, D = 2,775 mm



# POWER HOUSE

## 300L30 300L40

POWERHOUSE	300L30 BW	300L40 BW
Total heating capacity	371 kW	387 kW
Weight of Power House / technology	~ 1,800 kg / ~ 5,500 kg	
Weight of concrete base plate / steel substructure	~ 9,100 kg / ~ 2,800 kg	
Storage tank volume	2 x 1,600 litres	
Heat meter	optional	
Grid connection for heat	DN 65 / flange	
Supply cable	2 x [400V / 3Ph / 63A] + 2 x [230V / 1Ph / 16A] central.: Supply line 400V / 3Ph / 125A	
Fresh water / waste water connection	DN 20 / min. DN 70	
Fuel	Natural gas / biomethane / liquefied petroleum gas	
Maximum gas intake (LCV)	304.1 kW	327.0 kW
Heating demand	400,000 kWh/a	
Coverage share CHP	79.9 %	90.2 %
Heating demand	550,000 kWh/a	
Coverage share CHP	76.8 %	82.8 %
Heating demand	700,000 kWh/a	
Coverage share CHP	67.3 %	75.2 %
Heating demand	850,000 kWh/a	
Coverage share CHP	59.4 %	67.4 %

### PEAK LOAD BOILER

Thermal output, modulating (50/30 °C)	31.2 – 298.5 kW	31.2 – 298.5 kW
---------------------------------------	-----------------	-----------------

### COGENERATION UNIT

Manufacturer / model	EC POWER XRGI® 15	EC POWER XRGI® 20
Quantity	2	2
Condensing heat exchanger	Yes	Yes
Thermal output	2 x 38.7 kW = 77.4 kW	2 x 44.7 kW = 89.4 kW
Electrical output	2 x 14.5 kW = 29 kW	2 x 20.0 kW = 40.0 kW
Electricity ratio	0,395	0,447
Maximum flow temperature	~ 85 °C	~ 85 °C
Variable return temperature	5 °C to 70 °C	5 °C to 70 °C
Service interval (operating hours)	8,500	6,000



External dimensions: W = 6,000, H = 2,735, D = 3,000 mm

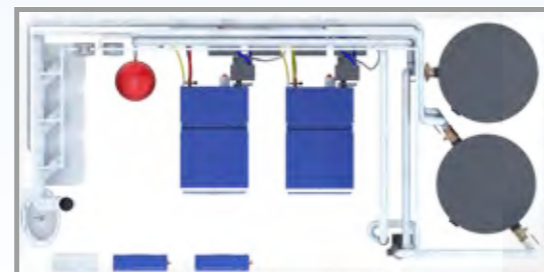

Internal dimensions: W = 5,775, H = 2,375, D = 2,775 mm

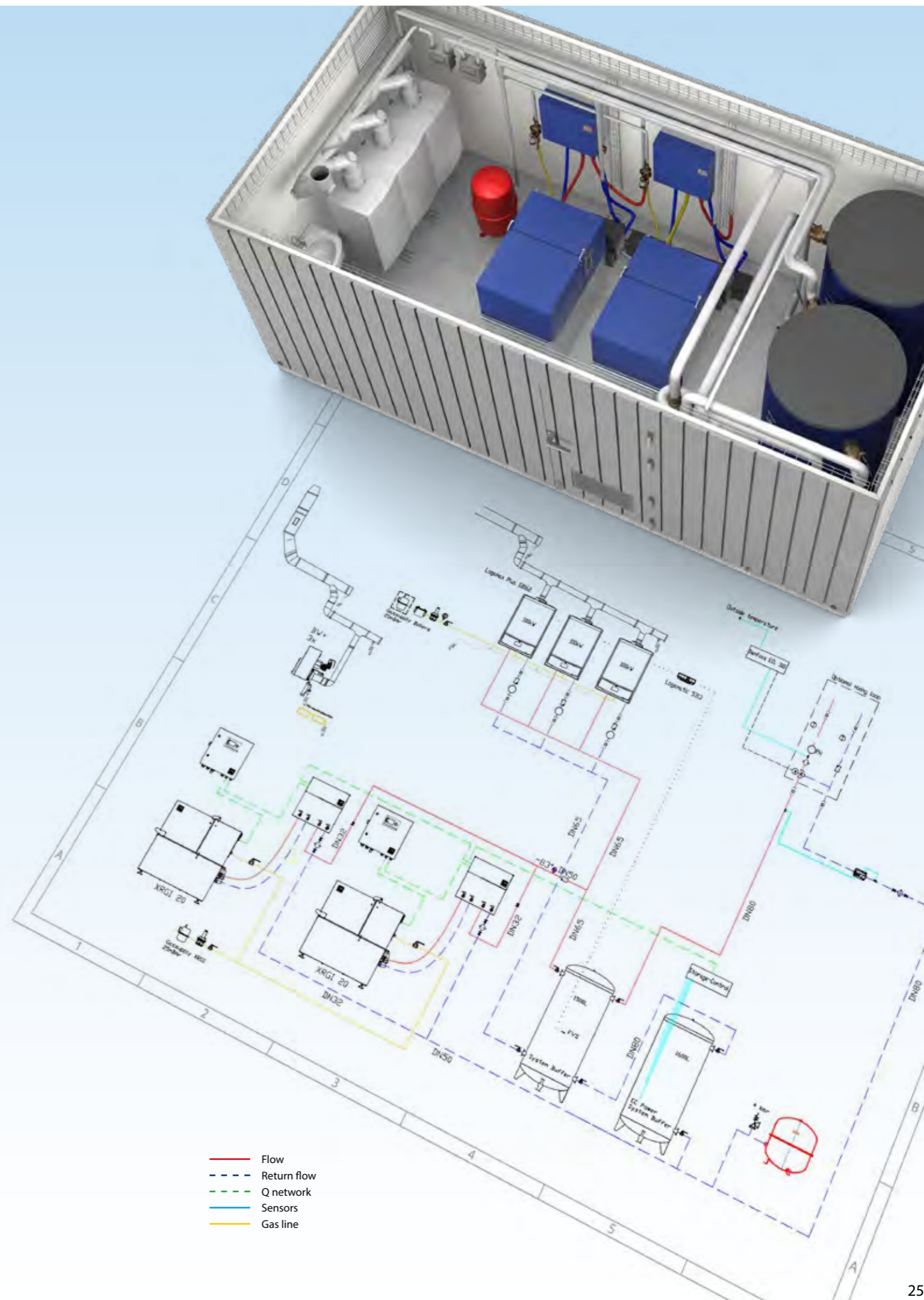



# POWER HOUSE

## 300L49

POWER HOUSE	300L49	300L49 BW
Total heating capacity	396 kW	411 kW
Weight of Power House / technology	~ 1,800 kg / ~ 6,000 kg	
Weight of concrete base plate / steel substructure	~ 9,100 kg / ~ 2,800 kg	
Storage tank volume	2 x 1,600 litres	
Heat meter	optional	
Grid connection for heat	DN 65 / flange	
Supply cable	2 x [400V / 3Ph / 63A] + [400V / 3Ph / 63A] + 2 x [230V / 1Ph / 16A] Central.: Supply line 400V / 3Ph / 125A	
Fresh water / waste water connection	DN 20 / min. DN 70	
Fuel	Natural gas / biomethane / liquefied petroleum gas	
Maximum gas intake (LCV)	460.1 kW	460.1 kW
Heating demand	600,000 kWh/a	
Coverage share CHP	82.8 %	86.4 %
Heating demand	800,000 kWh/a	
Coverage share CHP	73.4 %	78.6 %
Heating demand	1,200,000 kWh/a	
Coverage share CHP	64.3 %	70.3 %
Heating demand	1,200,000 kWh/a	
Coverage share CHP	57.0 %	62.8 %

### PEAK LOAD BOILER

Thermal output, modulating (50/30 °C)	31.2 – 298.5 kW	31.2 – 298.5 kW
---------------------------------------	-----------------	-----------------

### COGENERATION UNIT

Manufacturer / model	EC POWER XRGI® 20 + XRGI® 9	EC POWER XRGI® 20 + XRGI® 9
Quantity	2 x XRGI® 20 + 1 x XRGI® 9	2 x XRGI® 20 + 1 x XRGI® 9
Condensing heat exchanger	No	Yes
Thermal output	2 x 38.7 kW + 20.1 kW = 97.5 kW	2 x 44.7 kW + 23.3 kW = 112.7 kW
Electrical output	2 x 20.0 kW + 9.0 kW = 49.0 kW	2 x 20.0 kW + 9.0 kW = 49.0 kW
Electricity ratio	0.503	0.435
Maximum flow temperature	~ 85 °C	~ 85 °C
Variable return temperature	5 °C to 70 °C	5 °C to 70 °C
Service interval (operating hours)	10,000 / 6,000	10,000 / 6,000



External dimensions: W = 6,000, H = 2,735, D = 3,000 mm



Internal dimensions: W = 5,775, H = 2,375, D = 2,775 mm

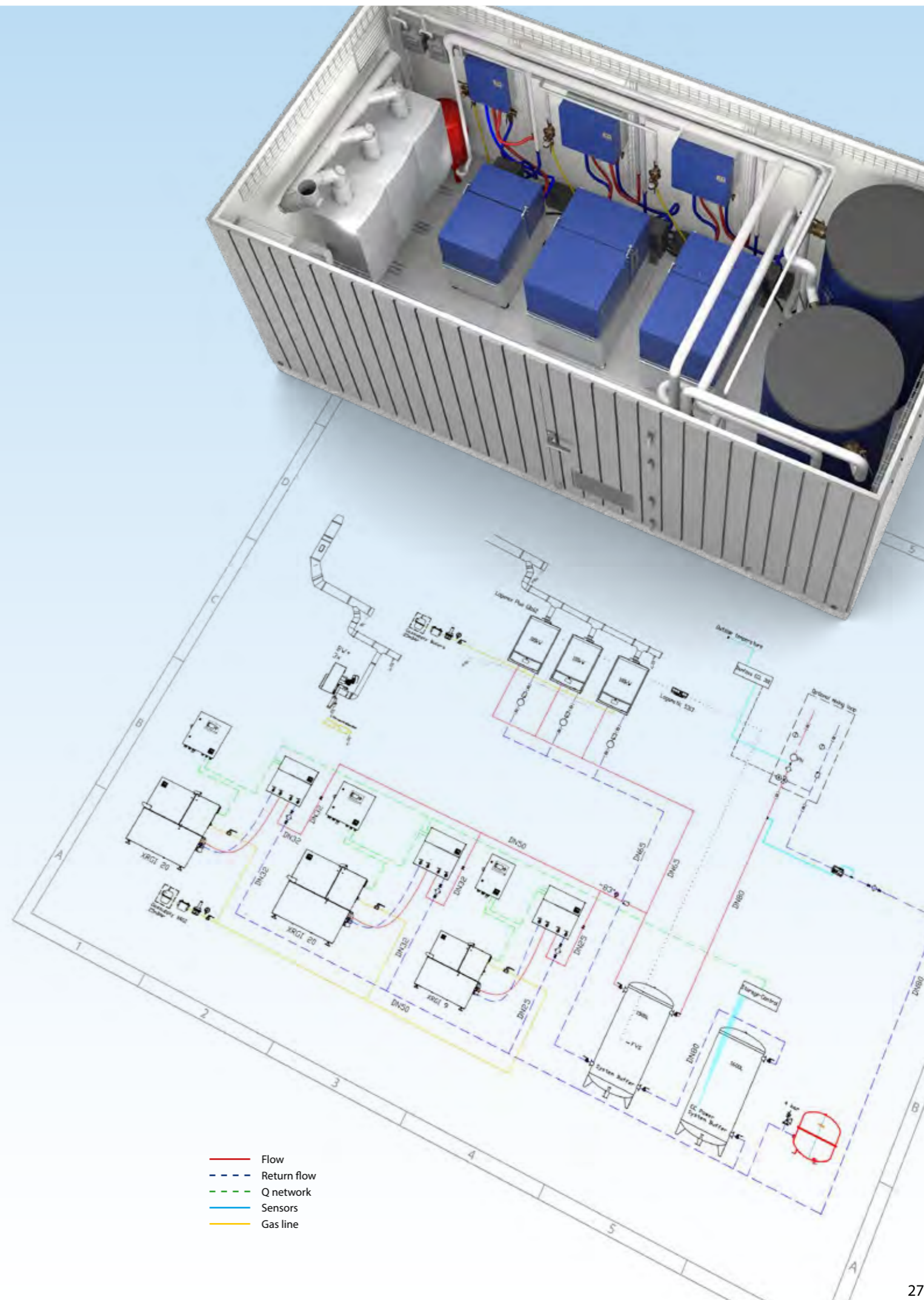

- Flow
- - - Return flow
- - - Q network
- Sensors
- Gas line





**EC POWER A/S**

Samsøvej 25  
8382 Hinnerup

Phone: +45 87 43 41 00

E-mail: [info@ecpower.dk](mailto:info@ecpower.dk)

**[WWW.ECPOWER.EU](http://WWW.ECPOWER.EU)**

